

KONTROLLÜ KOPYA SAYISI

Number of Controlled Copies

ONAY

Approval

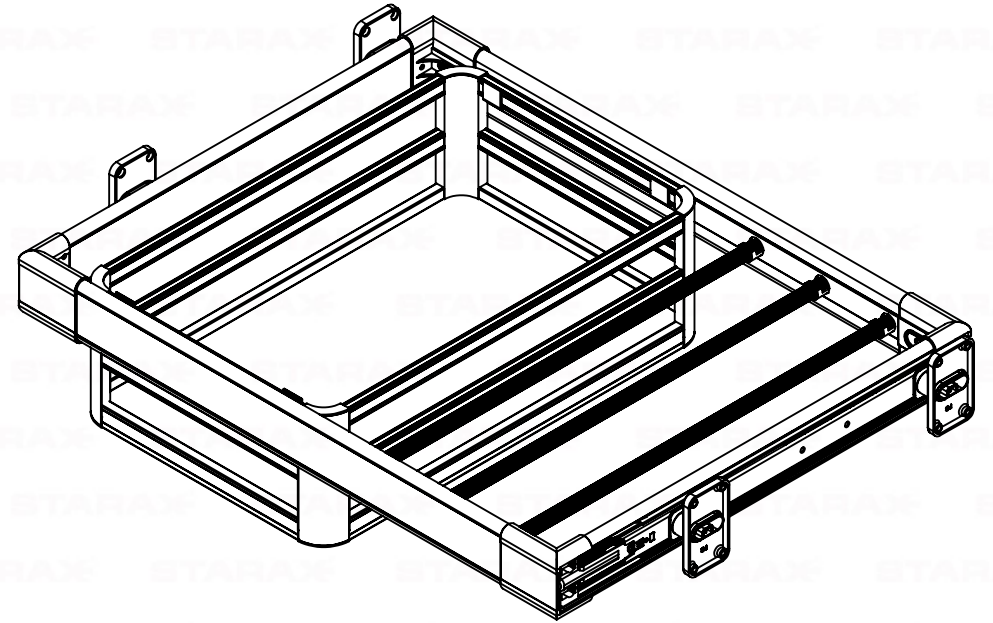
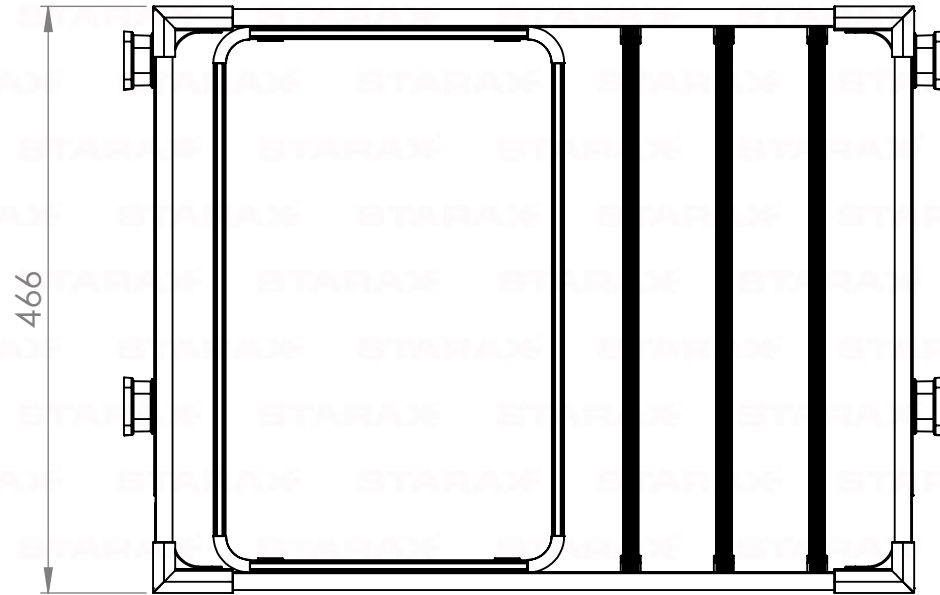
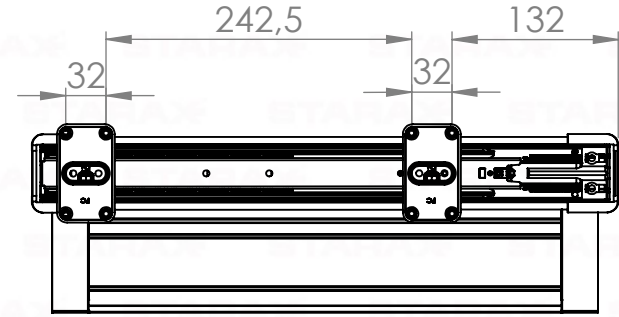
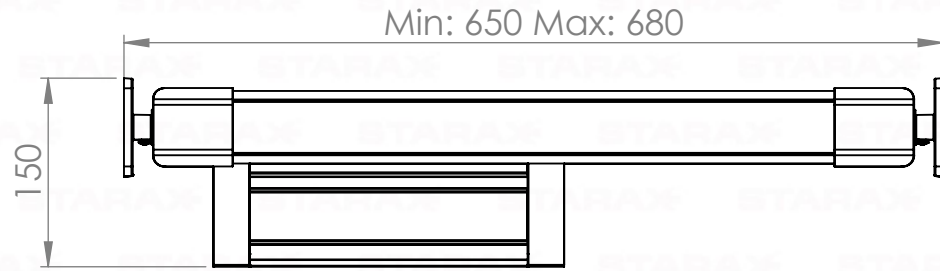

NOT: ÜRETİM İŞLEMİNDE KALİTE KONTROLÜN HIZLI DOĞRU ÖLÇÜM YAPABİLMESİ İÇİN ÖNEMLİ GEÇERLİK NOKTALARI A - B - C - D - E . VB HARFLERLE BELİRTİLMİŞTİR.

NOTE: Important points signed A, B, C, D, E etc for quality control in production works.

STARAX

ÇİZEN
Drawin By
KONTROL
Control
ONAY
Approval

Zeynep YAŞA
Tahsin ÖRNEK
Özgür ÇELEBİ

İMZA

Sing
Date
Date
Date

TARİH

4.02.2020
4.02.2020
4.02.2020

REVİZYON NO

Revision No
SAYFA NO
Paper No
MONTAJ NO
Assembly No
RESİM NO
Drawing No

REVİZYON TARİH

Revision Date
MALZEME
Material
MALZEME KODU
Material Code
MALZEME STOK KODU
Material Stock Code
PARÇA STOK KODU
Part Stock Code

KALIP KODU

Mold Code
MAKİNE KOD
Machine Code
İSTASYON KODU
Station Code
HACMI / KÜTLESİ
Volume of Mass
YÜZEY KALİTESİ
Surface Quality

mm³

N2 0,050µm
N1 0,025µm

PARÇA ADI

Part Name
TEKNİK RESİM AÇIKLAMASI
Drawing Description

Yan Bağlantılı Tls. Raylı Alüminyum Çekmeceli Pantolonluk 70 Cm

DETAYLARIYLA BELİRTİLMİŞ OLAN BU TEKNİK RESİM, **Star Mutfak ve Mobilya Aksesuarları San.ve Tic.A.Ş.**'nin İZİN OLAMADAN KOPLANIP ÇOĞALTILAMAZ ve 3. ŞAHISLARIN BİLGİLERİNE SUNULAMAZ.

AĞIRLIK
WEIGHT**BİRİM**
Unit**ÖLÇEK**
Scala**1:10**

Resimde verilmemiş toleranslar ±0,50mm dir. Bu Çizim TS 11398 Uygundur.
Tolerances not given in reilm are ±0,50mm.This Drawing is Suitable For TS 11398.

A4